

The new BMW X6



X6 xDrive35i
X6 xDrive35d

The Ultimate
Driving Machine



The coupé unshackled.
The new BMW X6.



Vehicle shown is BMW xDrive50i, planned availability 4th quarter 2008.



A breathtaking new turn for coupé design.

Vehicle shown is BMW xDrive50i, planned availability 4th quarter 2008.



Fire meets water.

Vehicle shown is BMW xDrive50i, planned availability 4th quarter 2008.

Leave the ordinary behind. Choose extraordinary.



Vehicle shown is BMW xDrive50i, planned availability 4th quarter 2008.
Please note 6-cylinder models have round tailpipes.

A new challenge to the tightest bends:
Dynamic Performance Control.



Vehicle shown is BMW xDrive50i, planned availability 4th quarter 2008.



Journey's end ...

And time to reflect on the birth of a captivating new concept.



Penetrating elegance. Into every detail.

Four doors are unusual enough for a Coupé.
For something really unique, just open one.





At night and when vision is poor, the low and high beam **Xenon headlights, fitted as standard**, provide optimal road illumination of the road ahead. The four light rings feature a daytime lighting function and can be used as parking lights. The optional **BMW light-alloy wheels in star-spoke 259** (top right) with mixed run-flat safety tyres are a particularly harmonious complement to the vehicle design. Measuring 10 J x 20 inch at the front with 275/40 R 20 tyres; and at the rear 11 J x 20 inch with 315/35 R 20

tyres. Standard on the X6 xDrive35i/35d is **BMW light-alloy wheels star-spoke 232** (lower left), 9 J x 19 inch with 255/50 R 19 run-flat safety tyres. The variable 570 litre-capacity **luggage compartment** offers plenty of room for four golf bags, for example. It can be extended to a capacity of 1,450 litres when the 60:40 dividable rear backrest is folded down. The collapsible luggage compartment cover can be stored under the compartment floor.

The optionally available active suspension system **Adaptive Drive** minimises body roll while boosting agility. Part of this equipment is a tighter suspension setting that can be selected by pressing the **Sport button**. A display shows how Dynamic Performance Control distributes drive force between the left and the right rear-wheels. The **Head-up Display** shows useful information such as current speed, right in the driver's field of vision. The height-adjustable display ensures that

nothing distracts you from the road ahead. And for the rear passengers, an independently operated **DVD system** is optionally available with a fold-down 8-inch LCD colour screen (please refer to footnote on page 17). It can be linked up to two headphones and an external video source. An optional wireless headset can be integrated via the infra-red interface provided.

■ Standard equipment □ Optional equipment — Not available

Safety	X6 xDrive35i	X6 xDrive35d
Active headrests, front	■	■
Airbags:		
– Driver and front passenger airbags (with seat occupancy detector)	■	■
– Head airbags (for front and 2nd row passengers)	■	■
– Side airbag for driver and front passenger, integrated into seat	■	■
Brakes:		
– Disc brakes front and rear, inner-vented	■	■
Central locking with electronic immobiliser, crash sensor	■	■
Dynamic Stability Control (DSC, incl. ABS, CBC and traction control DTC) with additional functions	■	■
Hill Descent Control (HDC)	■	■
Rollover sensor	■	■
Safety body shell:		
– Bumper system with impact cushions in aluminium at the front and steel at the rear; bumpers regenerate to their original shape in collisions at up to 4 km/h, deformation elements front and rear at up to 15 km/h	■	■
– Door-integrated side impact protection	■	■
Seat belts:		
– Ergonomic belt system at the rear with 3-point seat belts for both seats	■	■
– Inertia-reel seat belts with pyrotechnical belt tensioner and belt force governor	■	■

Exterior design	X6 xDrive35i	X6 xDrive35d
Aluminium running boards	□	□
Exterior mirrors in body colour , lower segment in black, tinted, electrically adjustable, aspherical and heated	■	■
Kidney grille with black slats and chrome surround	■	■
Metallic paintwork	□	□

Equipment packages	X6 xDrive35i	X6 xDrive35d
Sports package (includes Adaptive Drive, light-alloy wheels star-spoke 258 with mixed tyres, High-gloss shadowline and roofliner in Anthracite and ornamental front grille in grey)	□	□

--

■ Standard equipment □ Optional equipment — Not available

Wheels	X6 xDrive35i	X6 xDrive35d
– Light-alloy wheels star-spoke 232, 9 J x 19-inch, 255/50 R19 run-flat safety tyres	■	■
– Light-alloy wheels V-spoke 257, 9 J x 19-inch, 255/50 R 19 run-flat safety tyres	□	□
– Light-alloy wheels star-spoke 258 with mixed tyres, 9 J x 19-inch with 255/50 R 19 run-flat safety tyres at the front, 10 J x 19-inch with 285/45 R 19 run-flat safety tyres at the rear (only in conjunction with sports package)	□	□
– Light-alloy wheels Y-spoke 214 with mixed run-flat safety tyres, 10 J x 20-inch with 275/40 R 20 at the front, 11 J x 20-inch with 315/35 R20 tyres at the rear	□	□
– Light-alloy wheels star-spoke 259 with mixed run-flat safety tyres, 10 J x 20-inch with 275/40 R20 tyres at the front, 11 J x 20-inch with 315/35 R20 tyres at the rear	□	□

Interior design	X6 xDrive35i	X6 xDrive35d
Interior trims¹:		
– Fine-wood trim Bamboo Grain, dark	■	■
– Fine-wood trim Variegated Ash	■	■
– Flywheel Aluminium, black	■	■
– Brushed Aluminium, fine-grain	■	■
Upholstery:		
– Nevada leather	■	■
– Nevada leather perforated, only in conjunction with active seat ventilation	□	□
– Exclusive Nappa leather, extended	□	□

Transmission and technology	X6 xDrive35i	X6 xDrive35d
6-cylinder in-line diesel engine with four-valve technology	—	■
6-cylinder in-line petrol engine with four-valve technology	■	—
6-speed automatic transmission with Steptronic and gearshift paddles on sports leather steering wheel	■	■
Active steering incl. Servotronic	□	□
Diesel particle filter	—	■
Dynamic Performance Control , for targeted distribution of torque at the rear axle	■	■
Emissions standard: EU4	■	■
High Precision Injection (direct petrol injection)	■	—
Self-levelling with pneumatic rear suspension	□	□
Twin Turbo	■	—
VariableTwin Turbo	—	■
xDrive (all-wheel system with variable torque distribution)	■	■

¹ All trims are standard, however, one trim must be specified when ordering your vehicle.

■ Standard equipment □ Optional equipment — Not available

Driver assistance	X6 xDrive35i	X6 xDrive35d
Backup camera	■	■
Cruise control with brake function	■	■
Head-Up Display	■	■
High-beam assist	■	■
Park Distance Control (PDC), front and rear	■	■

Light and sight	X6 xDrive35i	X6 xDrive35d
Adaptive headlights with turning lights	■	■
Exterior mirror, with automatic anti-dazzle function, incl. fold-in function/autom. parking function	□	□
Foglamps with free-form reflector incl. heated front windscreen washer nozzles and exterior mirrors	■	■
Interior mirror with automatic anti-dazzle function	■	■
Lights package (incl. vicinity lights in exterior door handles, door pocket and interior door handle lighting, reading lights at the rear and footwell illumination)	■	■
Rain sensor	■	■
Xenon headlights for high and low beam incl. automatic headlight range control and four light rings (daytime driving and parking lights, incl. headlight washing system)	■	■

Interior	X6 xDrive35i	X6 xDrive35d
Automatic air conditioning, 2-zone (incl. AAR, condensation and solar sensors and residual heat function) with air outlets in the rear	■	■
Automatic air conditioning, 4-zone (with separate temperature control in the rear)	□	□
Grey shade band	■	■
Seats/seat comfort:		
– 4 seats, two rear seats in a sporty single-seat design with integrated headrests	■	■
– Active seat ventilation at the front	□	□
– Active seats for driver and passenger	□	□
– Comfort seats for driver and passenger, electric seat adjustment with additional functions, incl. lumbar support	□	□
– Lumbar support for driver and front passenger, electrically adjustable	□	□
– Rear seats, asymmetrically foldable (60:40)	■	■
– Seat adjustment, electric (with memory function for driver's seat and exterior mirrors)	■	■
– Seat heating for driver and front passenger	□	□
– Seat heating in the rear	□	□
– Sports seats for driver and front passenger	■	■
Steering column adjustment , electrical, vertical and horizontal	■	■
Steering wheels:		
– Sports leather steering wheel, three-spoke, multifunction	■	■

■ Standard equipment □ Optional equipment — Not available

Comfort and interior equipment	X6 xDrive35i	X6 xDrive35d
Comfort access system (for keyless entry and engine start)	■	■
Cupholders front and rear	■	■
Panoramic glass roof , electric, tilt/slide functions, convenient operation via vehicle key	□	□
Storage package (incl. 12-V power socket, luggage compartment nets and fastening rails with fastening points)	■	■
Start/Stop button	■	■
Tailgate, one piece	■	■
Tailgate, automatic operation	□	□

Entertainment, communication and information	X6 xDrive35i	X6 xDrive35d
Control Display	■	■
Controller	■	■
Favourite buttons	■	■
Navigation system:		
– Professional with 8.8" colour monitor, arrow and map display, CD and DVD drive for Navigation-DVD	■	■
– Preparation for mobile phone with Business Bluetooth interface	■	■
Radio/audio:		
– AUX-IN connection in centre console	■	■
– CD changer for six CDs, in glove compartment	■	■
– DVD system in the rear	□	□
– HiFi loudspeaker system	■	■
– HiFi system Professional	□	□
– Radio BMW Professional, incl. MP3-compatible CD drive	■	■
– USB/audio interface	■	■
Telematic services		
– BMW TeleAssist (free for one year)	■	■
TV function	■	■

Technical Data		X6 xDrive35i	X6 xDrive35d
Weight			
Kerb Weight ¹	kg	2070	2110
Permitted load	kg	600	600
Engine²			
Cylinder/valves		6/4	6/4
Capacity	cc	2979	2993
Max. output/engine speed	kW (hp) rpm	225 [306] 5800	210 [286] 4400
Max. torque/engine speed	Nm rpm	400 1300–5000	580 1750–2250
Performance			
Top speed	km/h	240	236
Acceleration 0–100 km/h	s	6.7	6.9
Fuel consumption³			
City	l/100 km	16.6	11.8
Highway	l/100 km	9.5	7.4
Combined	l/100 km	12.1	9.0

¹ The Kerb Weight or Unladen Mass is the mass of the vehicle in running order unoccupied and unladen with all fluid reservoirs filled to nominal capacity including fuel, and with all standard equipment.

² The petrol engines are designed for RON 98 fuel. They may also be run on RON 91 (X6 xDrive35i not less than RON 95) with a decrease in power output.

³ All engines meet the EU4 emissions standards. Fuel consumption is determined in accordance with the ECE driving cycle made up of approximately one third city and two thirds highway driving (based on the distance covered).

Fuel consumption is determined for vehicles with standard equipment. Optional equipment (such as wider tyres) can have a significant impact on fuel consumption.

Figures [] apply to vehicles with self-levelling and pneumatic rear suspension or in conjunction with Adaptive Drive.

The BMW X6 shown in this flyer has the exterior colour Vermilion Red metallic. The upholstery is in Nevada leather Oyster, with interior trim in fine wood Bamboo Grain, dark.

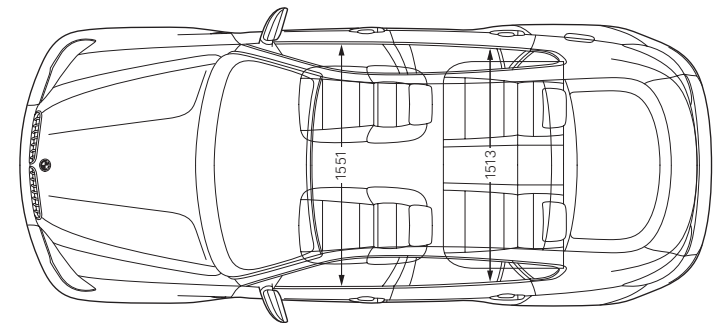
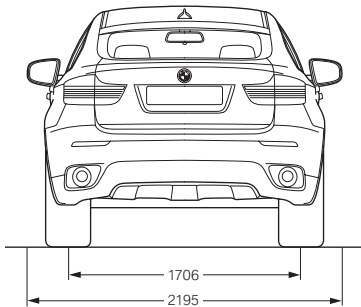
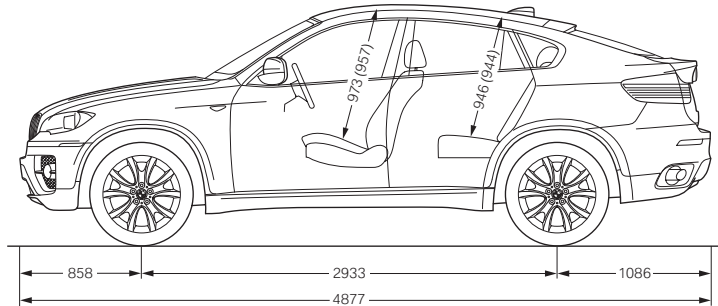
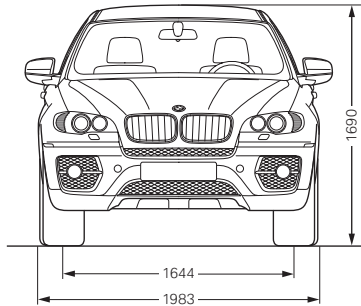

Measurements in () for vehicles with sunroofs.
 All dimensions in millimetres. Luggage compartment capacity (as per VDA standard): 570 – 1,450 litres.

More about BMW

Freecall
1800 813 299
www.bmw.com.au



The Ultimate
Driving Machine

The models illustrated in this brochure show the specifications for the Australian market. In part, they include optional equipment and accessories not fitted as standard. According to the specific requirements of other markets, alterations in models, standard and optional equipment, as described in this brochure, may occur. For precise information please contact your BMW Dealer. Subject to change in design and equipment. Subject to error.

© BMW AG, Munich/Germany. Not to be reproduced wholly or in part without written permission of BMW AG, Munich.